

SOLAR PUMP USER'S MANUAL

Item No.: AQUAJET-CUSTOM-KIT-24V-V1

1. OVERVIEW

- 1) The solar water pump is designed for water features and pond water filtration, and is powered by a solar module.
- 2) The solar module needs to be placed in the sunlight with its solar cells facing the sun as much as possible, and the performance of the pump depends on the sunlight intensity and the orientation of the solar module.
- 3) The latest DC brushless motor technology is introduced in the pump design and manufacturing, so that the pump has high efficiency and long service life.
- 4) The pump has a built-in function of dry-run protection. The dry-run protection function is provided by two sensor points on one side of the pump body (not visible from outside). The pump works if both of the points are submerged in water. If either or both points emerge out of water, the pump stops working.

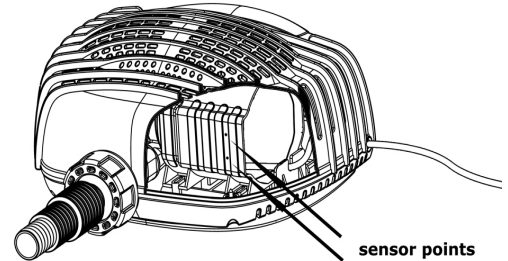

2. COMPONENTS

- 1) Solar panel with ground spike
- 2) Pump
- 3) Hose connection
- 4) Gland nut

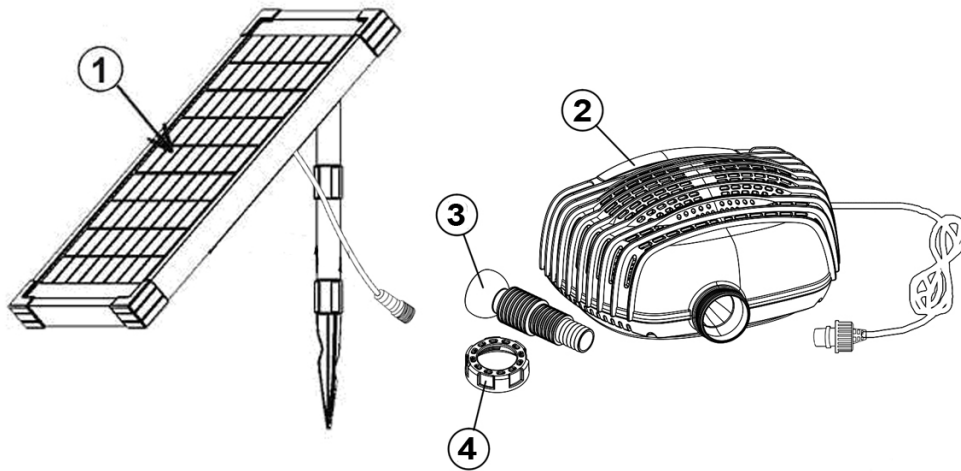

3. ASSEMBLING

- 1) Completely unroll the connecting cable on the stream pump.
- 2) Attach the hose onto the outlet of the hose connection. The hose connection is suitable for various hose diameters (inside diameter 25,32 or 38 mm).
- 3) Mount the hose connection to the pump outlet by means of the enclosed gland nut. Via the ball joint, the angle of the hose connection may be adjusted under water when necessary.
- 4) Completely immerse the stream pump into the water.
- 5) Connect the pump to the solar panel, and tighten the screw for protection.
- 6) Install the solar panel in garden lawn or soft ground by means of the spike and adjust the angle to face the solar modules toward the sun.
- 7) The solar pump is now ready to operate.

3. CAUTIONS

- 1) Any altering of the product itself or changing of the components voids warranty.
- 2) Do not connect the pump to any AC voltage power directly; it's ONLY for DC voltage power.
- 3) Operate the pump in water only (never above 40°C), especially keep it away from flammable liquids.
- 4) All the connectors are protected against reverse polarity as shown in the right figure. Don't insert the plug with reverse polarity by using unnecessary force.
- 5) The pump is dry run protected. The pump will automatically stop when there is no enough water.

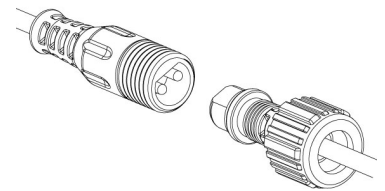

5. CLEANING AND MAINTENANCE

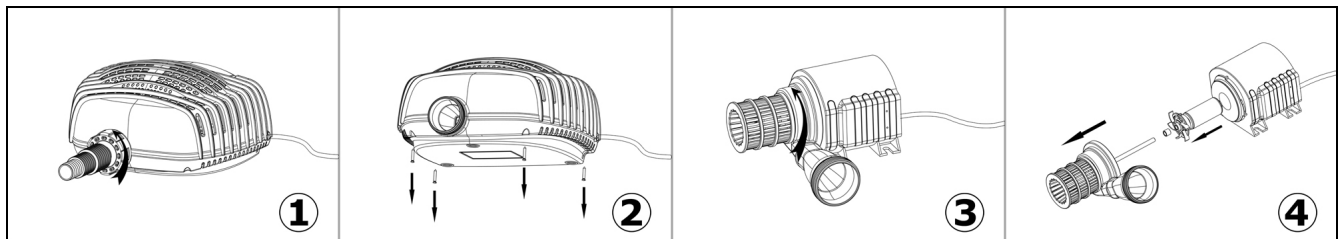

If the pump starts losing power or stops working after operating for a certain time, please clean up the sediment inside the pump or the debris on the filter cribs.

The pump can be opened by unscrewing the four screws on the four corners of the filter housing bottom.

To clean the pump, disassemble the pump according to the above figure and then clean all parts with water.

Be careful, never drop down the ceramic axis while cleaning the impeller, it breaks easily.



6. TROUBLE SHOOTING

Pump does not operate, please check the following possible reasons:

- 1) No connection to the power supply.
- 2) Impeller is blocked—to clean the pump as described in “**CLEANING AND MAINTENANCE**”.
- 3) To be sure the pump is fully submerged in water.

***Pump does operate but there is no water running through the tubes: Clear the tube and the filter to make sure the tube is through completely.**

7. TECHNICAL DATA AND PUMP CURVE

Peak Power of Solar Panel	25W
Operating voltage	18V
Maximum pump head	2.1m
Maximum flow rate	2480L/H
Cable length	5 M

AquaJet™ 24V Custom Kit

Pump Lift vs. Flow Rate

